

PART NAME - NUMBER

LARGE SUPERSPRING BOX INSERT - 112306

INSERT INFORMATION

BUILT DIMENSIONS

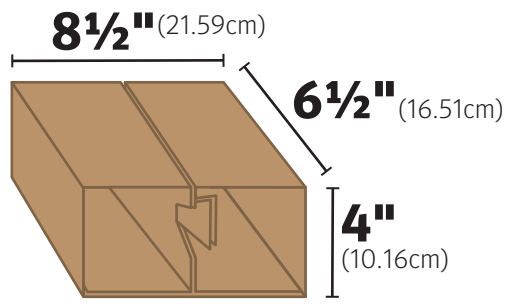

BOX INSERT DESCRIPTION

Large SuperSpring Box Insert

BOX INSERT NUMBER

112306

INSERT ASSEMBLY

1. Verify that the box insert is free of dust, debris, tears, and punctures. Insert must be in excellent condition before assembly. Handle with care, making sure you don't damage or introduce dirt to the insert.
2. With the insert laying flat on the table, using the pre-scored sections fold the end sections up.

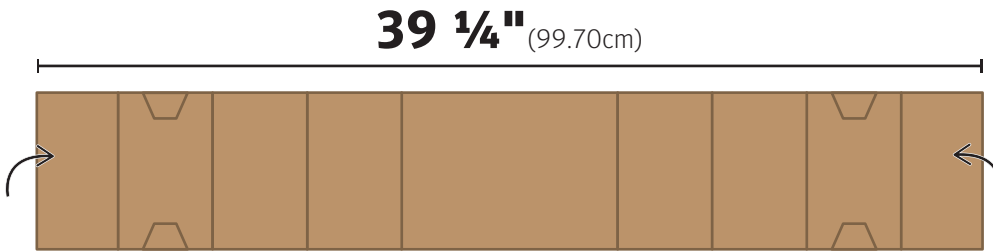

3. With the side sections folded up, continue folding the side sections in, each at a 90° angle, until they meet in the middle.

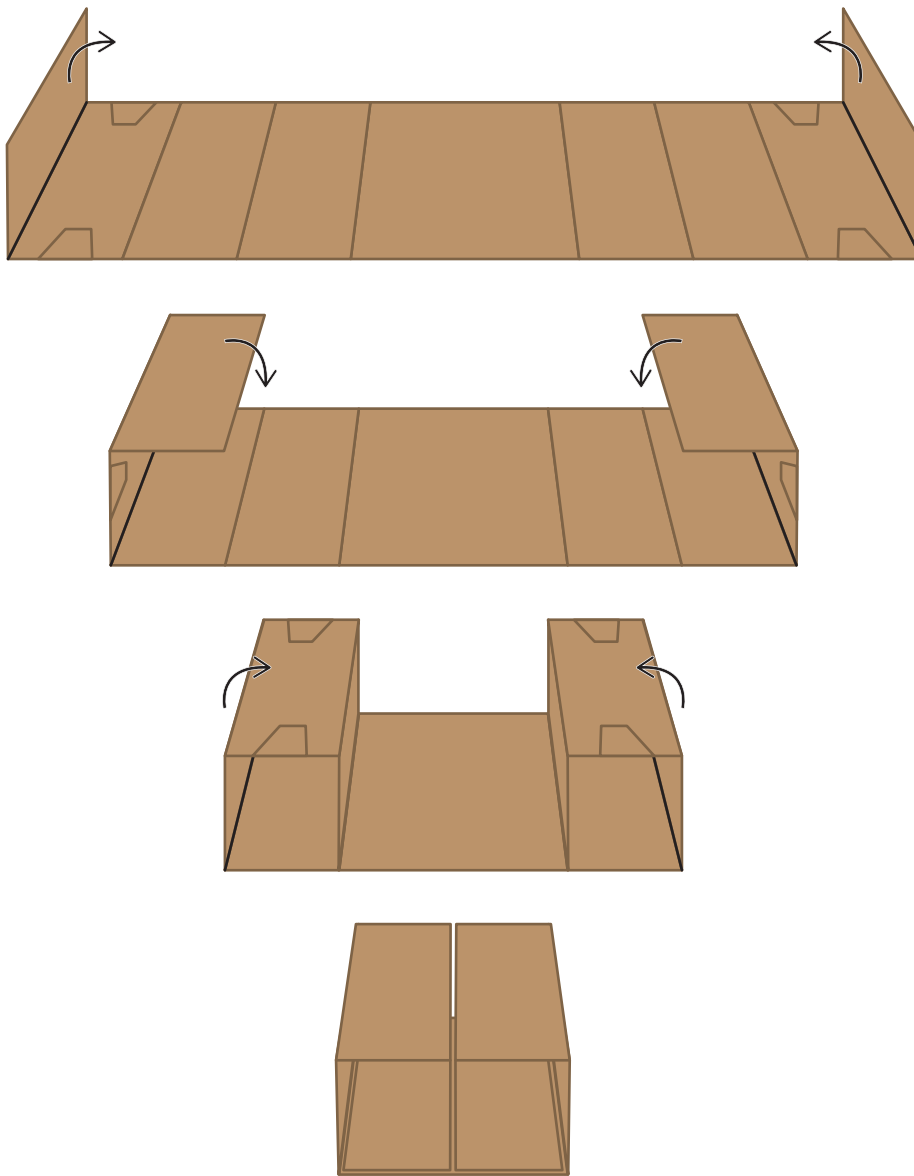

4. Once the two ends have met in the middle, secure them by folding over the tabs in the center sections of the insert on the end. Repeat this step on the other end of insert.

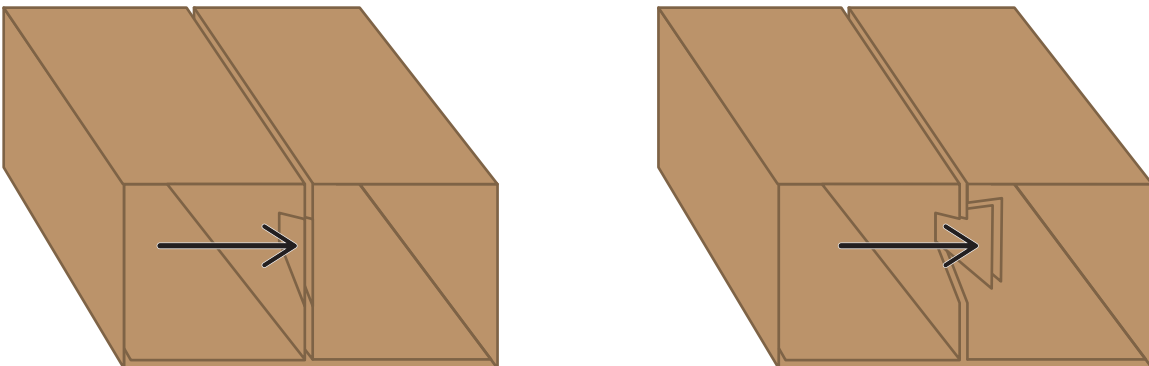

5. Once the box insert is complete, continue with the instructions as directed in the applicable Build Guide.

COMPLETED INSERT

