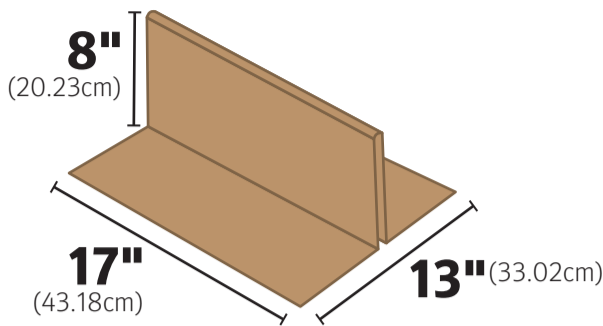


PART NAME - NUMBER

**SMALL SUPERCOIL BOX INSERT - 220011**

**INSERT INFORMATION**

**BUILT DIMENSIONS**



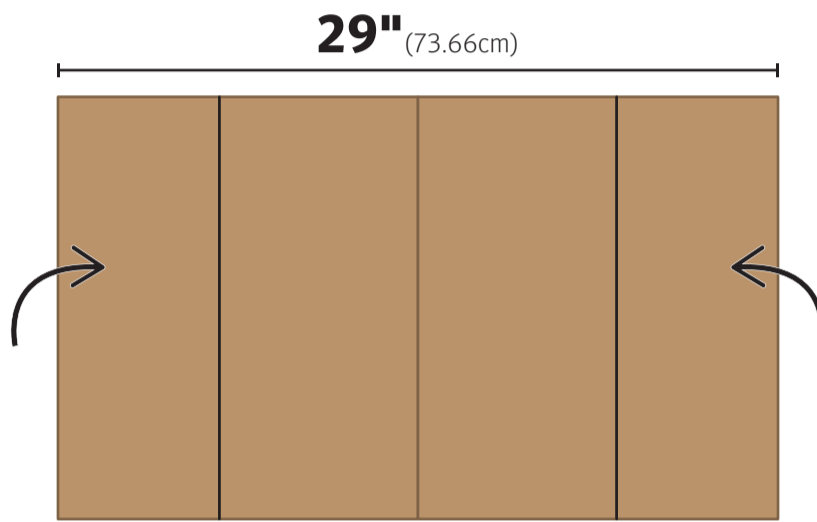
**BOX INSERT DESCRIPTION**  
Small SuperCoil Box Insert

**BOX INSERT NUMBER**  
220011

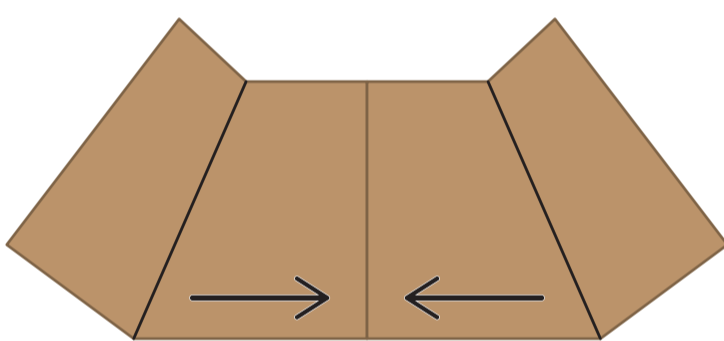
**INSERT ASSEMBLY**

1. Verify that the box insert is free of dust, debris, tears, and punctures. Insert must be in excellent condition before assembly. Handle with care, making sure you don't damage or introduce dirt to the insert.

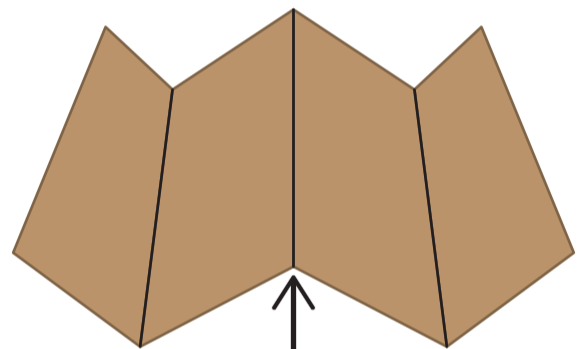
2. With the insert laying flat on the table, using the pre-scored sections fold the end sections up.



3. With the side sections folded up, push the bottom of the side sections together (DIAGRAM A), raising the middle score line up (DIAGRAM B), until the center sections meet in the middle.

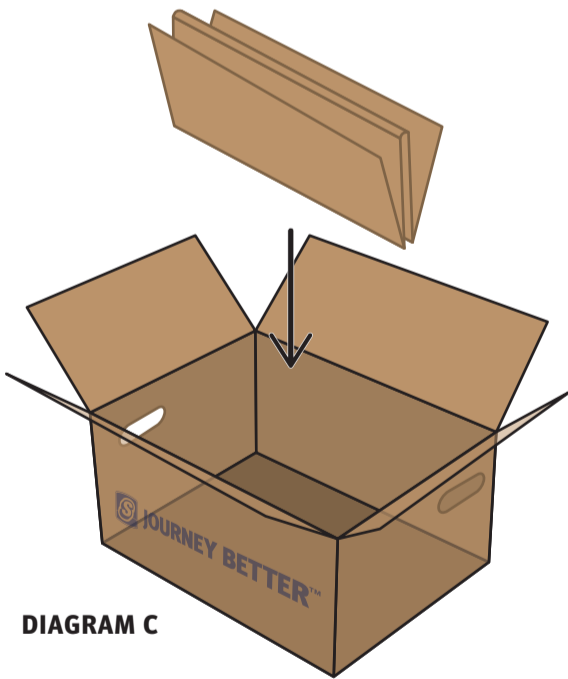


**DIAGRAM A**

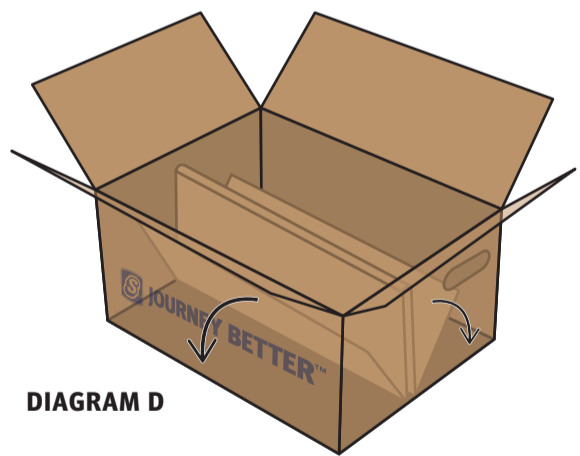


**DIAGRAM B**

4. Once the two center sections have met in the middle, hold the middle and both side sections together and place the insert into the box (DIAGRAM C). Once the bottom edges of the insert hit the bottom of the box, lower the side sections until they are flat in the box (DIAGRAM D).



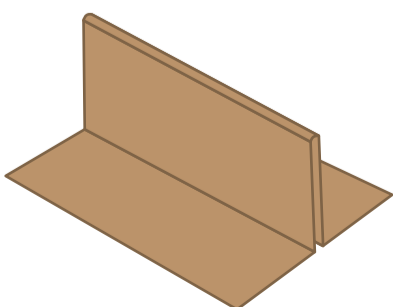
**DIAGRAM C**



**DIAGRAM D**

5. Once the box insert is complete, continue with the instructions as directed in the applicable Build Guide.

**COMPLETED INSERT**



**COMPLETED INSERT IN BOX**

