

PART NUMBER
SSR-180-54-1

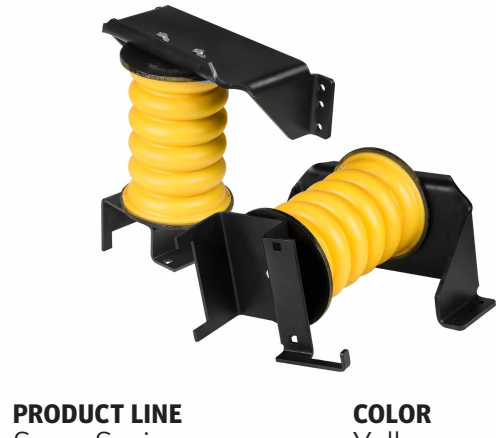

PRODUCT INFORMATION



PRODUCT LINE
SumoSprings

COLOR
Yellow

VARIATION
Maxim

BOX INFORMATION

SHIPPING DIMENSIONS

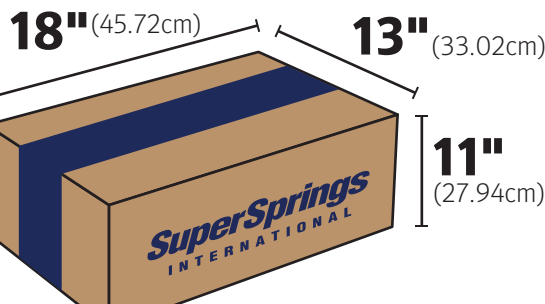

BOX DESCRIPTION
Large SumoSprings Box

TAPE MACHINE POSITION
#30 // 28" (71.12cm)

BOX NUMBER
512506

BILL OF MATERIALS

Item	Part #	Description	QTY
A	511401	SumoSprings Yellow -54	2
B	512037	Upper Mounting Bracket	2
C	512108	Lower Mounting Bracket	2
D	512042	U-Bracket Strap	2
E	512207	3/8-16 x 3/4" Serrated Flange Hex Bolt	6
F	512301	3/8-16 x 1 1/2" Flange Hex Bolt	8
G	512247	3/8-16 x 4" Carriage Bolt	4
H	512302	3/8-16 Top Lock Flange Nut	12
I	512506	Large SumoSprings Box	1
J	122363	S-Badge Sticker	1
K	122366	SumoSprings Logo Sticker	1
L	122369	Warranty Card	1
M	INS_SSR-187-40-1/54-1	Install Guide	1

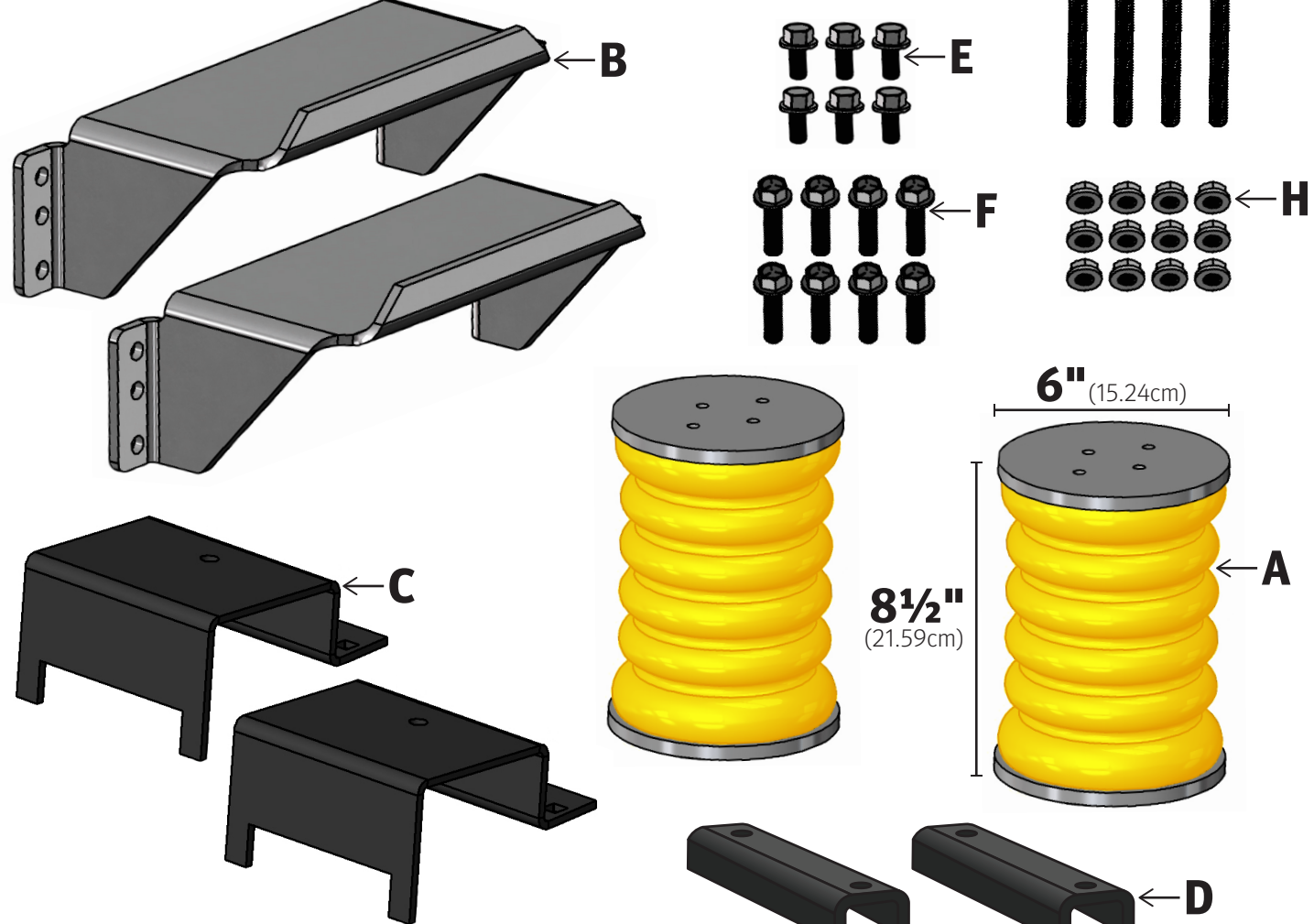
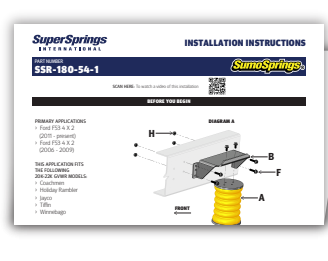

TOOLS REQUIRED

- > Protective gloves
- > Safety glasses
- > Filler paper machine
- > Filler paper
- > Heat sealer
- > 8" (20.32cm) Plastic tubing
- > Metal ruler
- > Protectant cleaner
- > Microfiber towel

BEFORE YOU BEGIN

PLEASE NOTE

All of the following steps that are highlighted in yellow require you to wear protective gloves and safety glasses to complete.

PACKING INSTRUCTIONS

- Print or retrieve one set of installation instructions per kit. Always use the current, approved, document revision.
- Fold instructions in half, placing the warranty card and stickers within the folded document. Set them aside.
- Locate and review components needed to build kit as listed in the Bill of Materials section.
- Start by building the kit box according to the Box Guide.
- Retrieve the filler paper machine and carefully release and cut 9" (22.86cm) of filler paper. Place one part D U-bracket on the filler paper with the U up, cover with the end of the filler paper, then place the second U-bracket on top of the first with the U down (DIAGRAM A). Roll the brackets, wrap the paper around them until you get to the end (DIAGRAM B). Then fold the ends of the paper down tucking them under the brackets (DIAGRAM C).

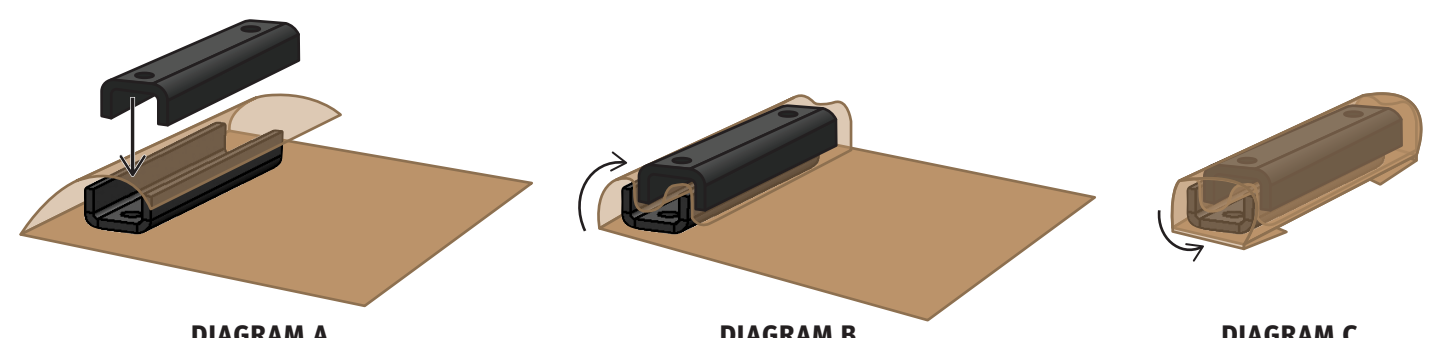

- Retrieve the 8" (20.32cm) wide plastic tubing to create a small bag for kit accessories.
- Using the heat sealer, set the heat settings at #4. Measure the roll to 6" (15.24cm), press sealer arm down across the plastic roll for 2 seconds to create a sealed closure (HEAT SEAL 1). Press the cut button to release the roll, creating a bag.

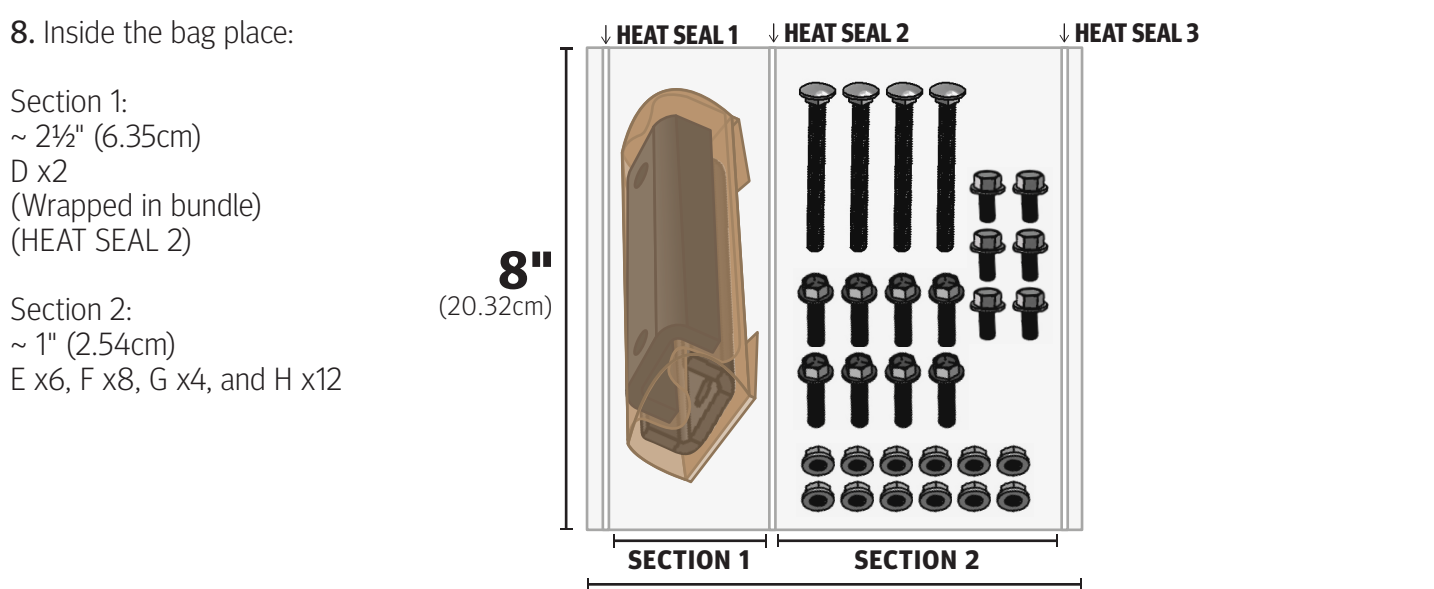

- Insert the opening of the bag into the heat sealer and repeat step 7 to seal the bag closed (HEAT SEAL 3). Set bag aside.

- Using the filler paper machine, carefully release and cut 5' (152.40cm) x 8" (10.32cm) of filler paper. Place one part B upper mounting bracket on the filler paper, covering it with the end of the filler paper (DIAGRAM D). Wrap the filler paper around the bracket until you get to the end of the paper (DIAGRAM E). Fold the ends of the paper down on the sides around the bracket if needed. Repeat process for second part B upper mounting bracket.

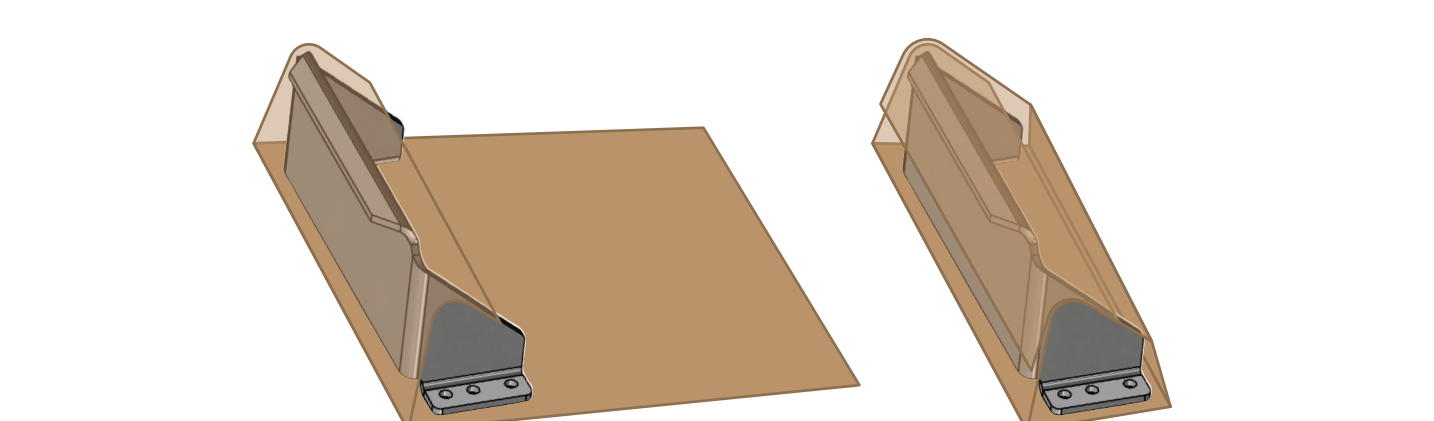

- Using the filler paper machine, carefully release and cut 7' (213.36cm) of filler paper. Place one part C lower mounting bracket on the filler paper, cover with the end of the filler paper, then place the second lower bracket on top of the first (DIAGRAM F). Wrap the filler paper around the brackets until you get to the end of the paper (DIAGRAM G). Then fold the ends of the paper down tucking them under the brackets (DIAGRAM H).

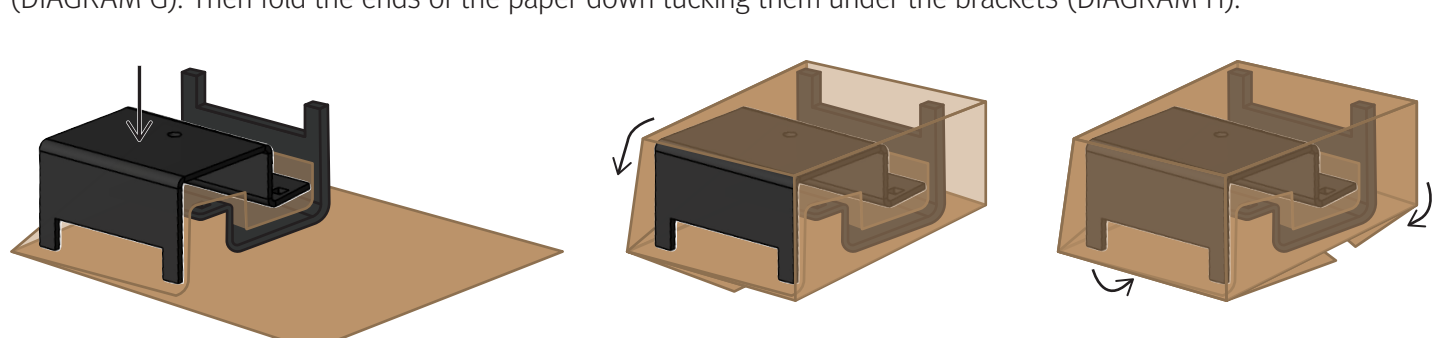

- Visually inspect the height of the two SumoSprings, and ensure they match each other. If not, select another component until both match in height. If needed, use the metal ruler for assistance with accuracy.

- Using a microfiber towel and a small amount of protectant cleaner, wipe clean the SumoSprings of any dust or debris. Set aside the SumoSprings.

- Place the SumoSprings inside the box on the right side (refer to diagram below). Place the two wrapped Part B upper mounting brackets on the left side of the box with the angled sides together and the corner aligned with the box. Using the filler paper machine, release enough paper to fill the space in between the SumoSprings and brackets in the box. The SumoSprings and brackets should fit snug with little to no movement (DIAGRAM I). Add filler paper on top of the SumoSprings and upper mounting brackets, then place the wrapped part C lower brackets to the left, on top of the SumoSprings (DIAGRAM J).

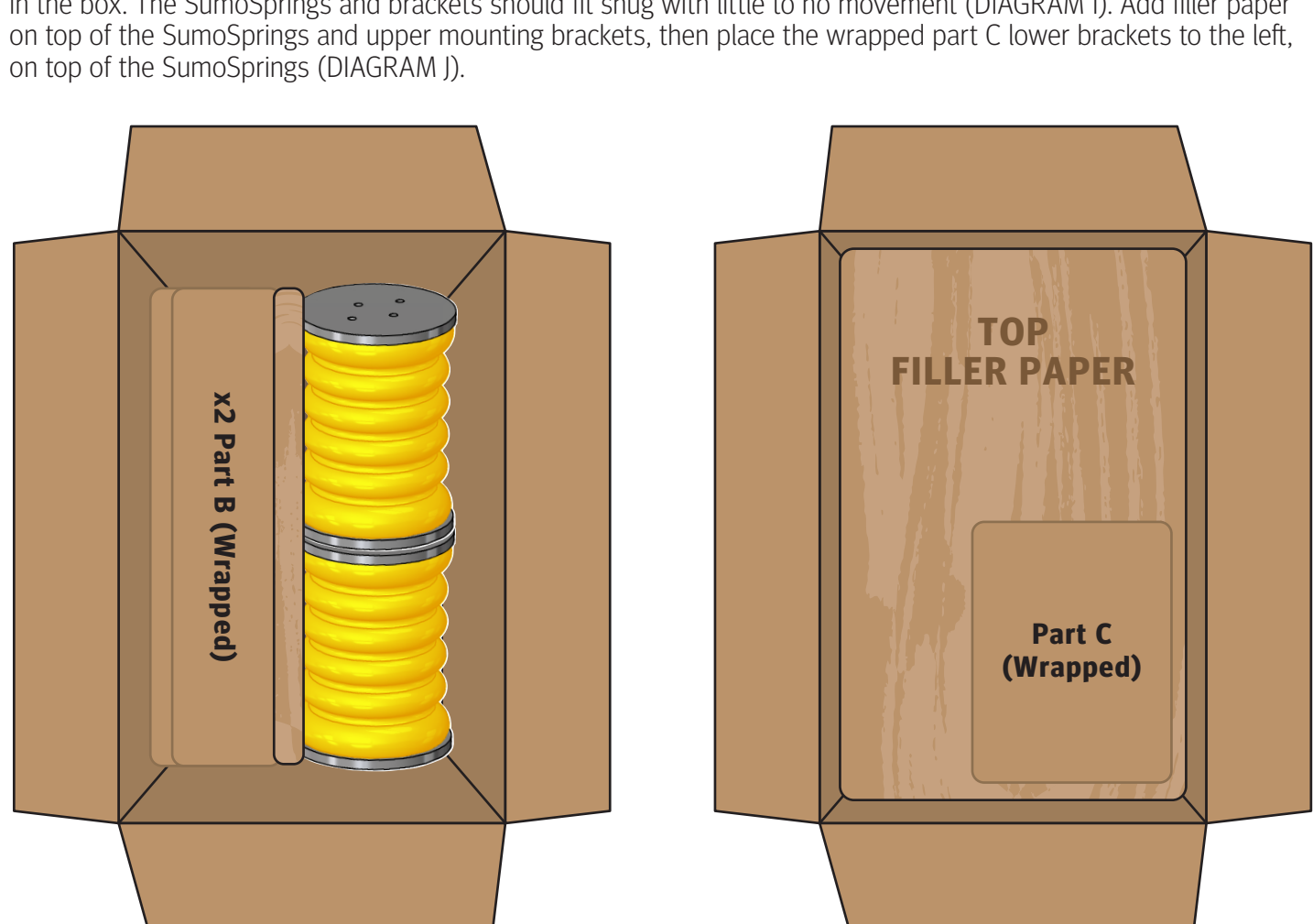

- Place the 8" (20.32cm) bag with the accessories in the box, to the left on top of the upper mounting brackets.

- Retrieve the installation instructions packet, which should contain the warranty card and SSI sticker, and place it on top of the components in the box.

- Close the top of the box by completing the steps referenced in the Box Guide.

- Using the scanner (refer to scanner instructions) print out a label.

- Position label vertically, on the left side of the end of the box with the SuperSprings International logo side to the left (refer to Completed Kit Diagram).

- Place the finished kit in the applicable bin.

COMPLETED KIT



COMPLETED KIT WEIGHT
38lbs (17.24 kg.)