

PART NUMBER
SSR-330-47



PRODUCT INFORMATION



PRODUCT LINE
SumoSprings
VARIATION
Solo

COLOR
Black

BOX INFORMATION

SHIPPING DIMENSIONS

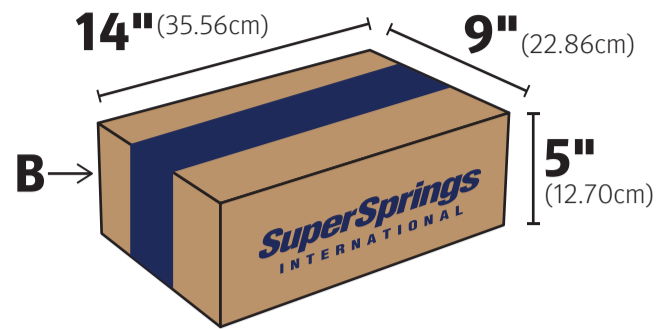

BOX DESCRIPTION
Medium SumoSprings Box
BOX NUMBER
512509

TAPE MACHINE POSITION
#20 // 18" (45.72cm)

BILL OF MATERIALS

Item	Part #	Description	QTY
A	511479	SumoSprings Black -47	2
B	512509	Medium SumoSprings Box	1
C	122363	S-Badge Sticker	1
D	122366	SumoSprings Logo Sticker	1
E	122369	Warranty Card	1
F	INS_SSR-330-47	Install Guide	1

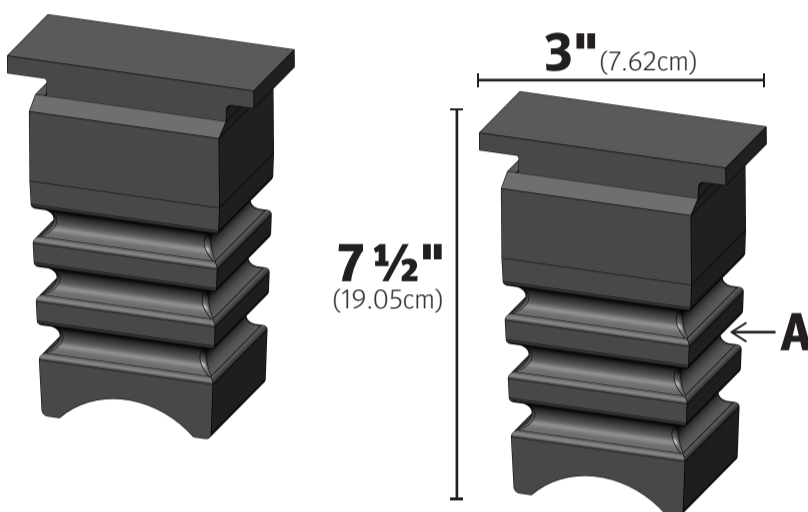
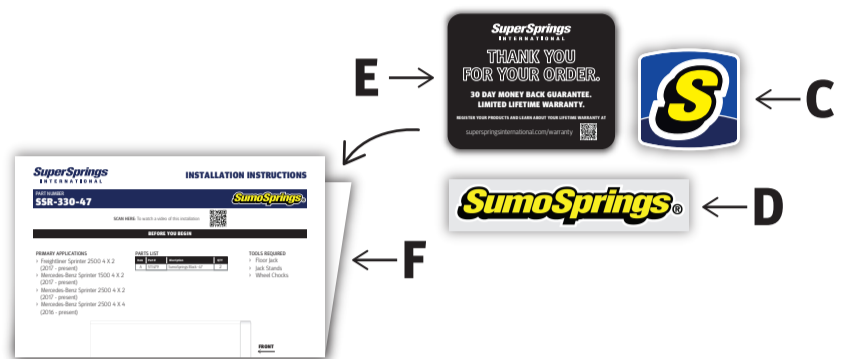

TOOLS REQUIRED

- > Protective gloves
- > Safety glasses
- > Metal ruler
- > Protectant cleaner
- > Microfiber towel
- > Filler paper machine
- > Filler paper

BEFORE YOU BEGIN

PLEASE NOTE

All of the following steps that are highlighted in yellow require you to wear protective gloves and safety glasses to complete.

PACKING INSTRUCTIONS

1. Print or retrieve one set of installation instructions per kit. Always use the current, approved, document revision.
2. Fold instructions in half, placing the warranty card and stickers within the folded document. Set them aside.
3. Locate and review components needed to build kit as listed in the Bill of Materials section.
4. Start by building the kit box according to the Box Guide.
5. Visually inspect the height of the two SumoSprings, and ensure they match each other. If not, select another component until both match in height. If needed, use the metal ruler for assistance with accuracy.
6. Using a microfiber towel and a small amount of protectant cleaner, wipe clean the SumoSprings of any dust or debris. Set aside the SumoSprings.
7. Place the SumoSprings inside the box vertically, in opposite directions, on the right side (refer to diagram below). Using the filler paper machine, release enough paper to fill the space on the left side of the box. The SumoSprings should fit snug with little to no movement.

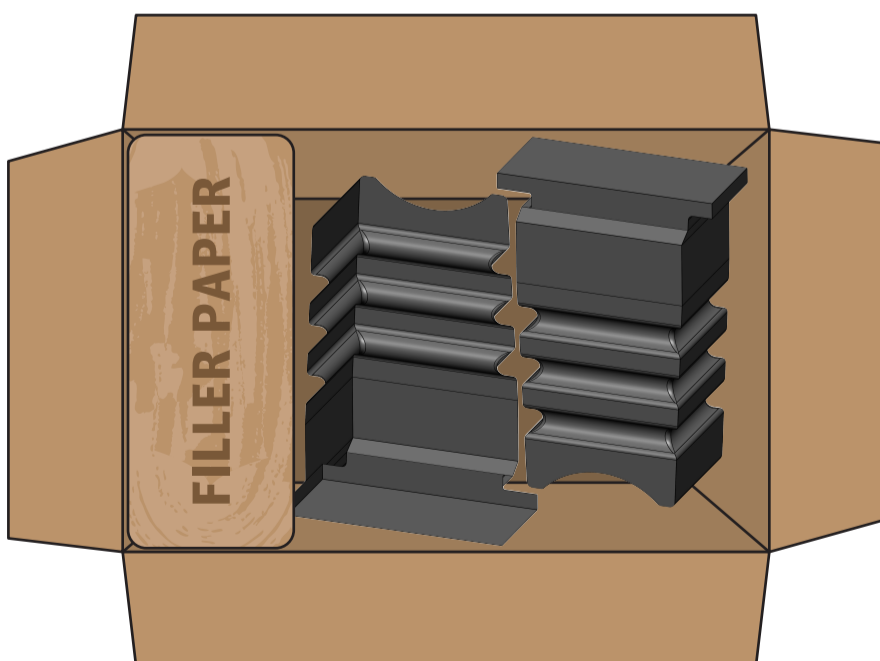

8. Retrieve the installation instructions packet, which should contain the warranty card and SSI sticker, and place it on top of the components in the box.

9. Close the top of the box by completing the steps referenced in the Box Guide.

10. Using the scanner (refer to scanner instructions) print out a label.

11. Position label vertically, on the left side of the end of the box with the SuperSprings International logo side to the left (refer to Completed Kit Diagram).

12. Place the finished kit in the applicable bin.

COMPLETED KIT



COMPLETED KIT WEIGHT
5lbs (2.27 kg.)