

PART NUMBER
SSR-610-40



PRODUCT INFORMATION



PRODUCT LINE
SumoSprings
VARIATION
Solo

COLOR
Blue

BOX INFORMATION

SHIPPING DIMENSIONS

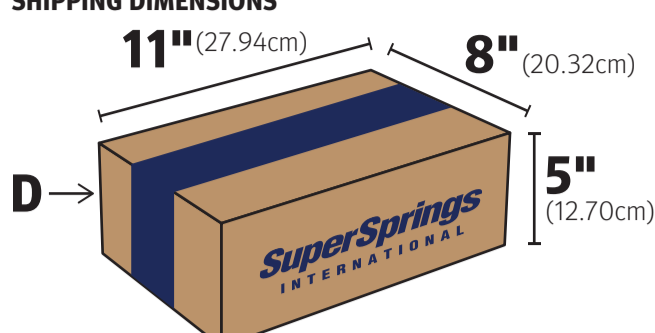

BOX DESCRIPTION
Small SumoSprings Box
BOX NUMBER
512502

TAPE MACHINE POSITION
#18 // 16" (40.64cm)

BILL OF MATERIALS

Item	Part #	Description	QTY
A	511440	SumoSprings Blue -40	2
B	512094	Mounting Bracket	2
C	512239	Blue Thread Locker	1
D	512502	Small SumoSprings Box	1
E	122363	S-Badge Sticker	1
F	122366	SumoSprings Logo Sticker	1
G	122369	Warranty Card	1
H	INS_SSR-610-40/47/54	Install Guide	1

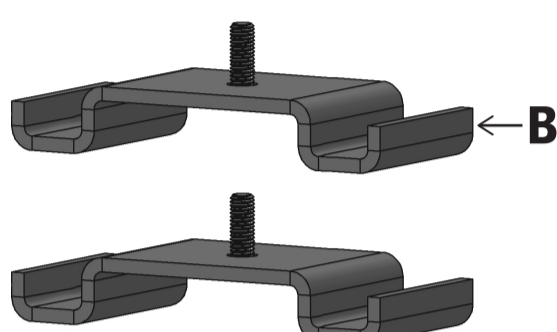
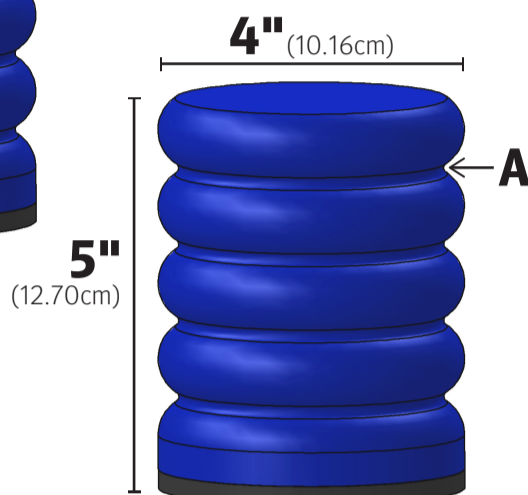
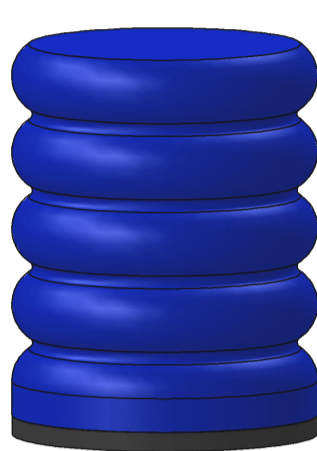
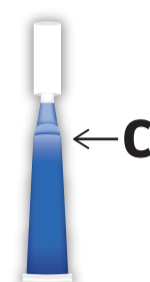
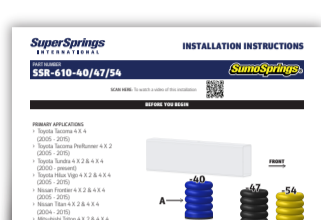

TOOLS REQUIRED

- > Protective gloves
- > Safety glasses
- > Heat sealer
- > 4" (10.16cm) Plastic tubing
- > Metal ruler
- > M-8 x 1.25 drill bit
- > Handheld drill
- > Air hose/compressed air
- > Protectant cleaner
- > Microfiber towel
- > Filler paper machine
- > Filler paper

BEFORE YOU BEGIN

PLEASE NOTE

All of the following steps that are highlighted in yellow require you to wear protective gloves and safety glasses to complete.

PACKING INSTRUCTIONS

1. Print or retrieve one set of installation instructions per kit. Always use the current, approved, document revision.
2. Fold instructions in half, placing the warranty card and stickers within the folded document. Set them aside.
3. Locate and review components needed to build kit as listed in the Bill of Materials section.
4. Start by building the kit box according to the Box Guide.
5. Retrieve the 4" (10.16cm) wide plastic tubing to create a small bag for the Blue Thread Locker.

6. Using the heat sealer, set the heat settings at #4. Measure the roll to 1 1/2" (3.81cm), press sealer arm down across the plastic roll for 2 seconds to create a sealed closure (HEAT SEAL 1). Press the cut button to release the roll, creating a bag.

7. Inside the bag place:
C x1

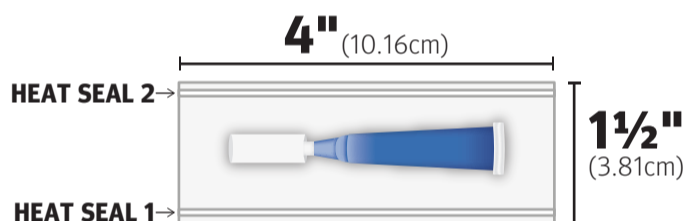

8. Insert the opening of the bag into the heat sealer and repeat step 6 to seal the bag closed (HEAT SEAL 2). Set bag aside.

9. Visually inspect the height of the two SumoSprings, and ensure they match each other. If not, select another component until both match in height. If needed, use the metal ruler for assistance with accuracy.

10. SumoSprings will need to have the thread cleaned. For this, use the hand drill and a M-8 x 1.25 drill bit.

11. On the hand drill, turn drill speed to the #1.

12. Place the M-8 x 1.25 drill bit into the thread of the SumoSprings approximately 3/4" to 1" (1.91 - 2.54cm). Thread is located at the top center of the SumoSprings component. Turn drill on until the glue and plastic are removed from the thread. Approximate drill time is 2 to 5 seconds. Once complete, make sure the drill is turned off in a secure location.

13. Using the air hose, or compressed air, clean off the SumoSprings for any residue left over from drilling. Place the air hose, or compressed air, back in its secure location.

14. Using a microfiber towel and a small amount of protectant cleaner, wipe clean the SumoSprings of any dust or debris. Set aside the SumoSprings.

15. Retrieve the filler paper machine and carefully release enough paper to wrap two part B brackets (refer to diagrams below). With the paper on the table put the first bracket down, then take the top of the paper and cover the top of the first bracket, place the second bracket on top of the first with the paper in between (DIAGRAM A). Take the bottom of the paper and wrap it around both brackets (DIAGRAM B). Fold the ends of the paper on each side down and under the brackets to secure them (DIAGRAM C).

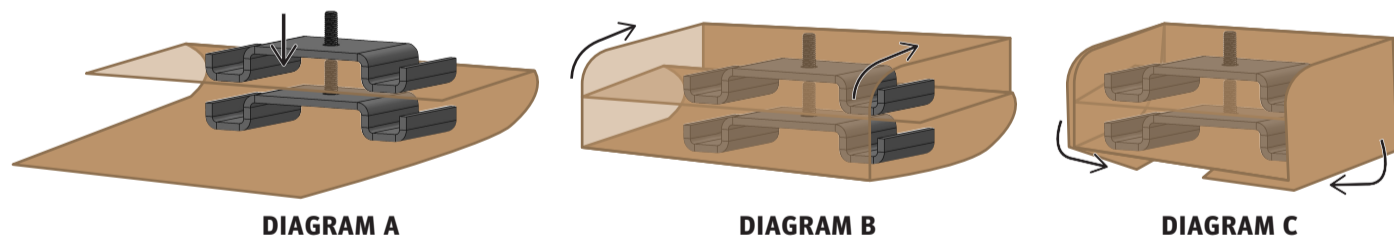

16. Place the SumoSprings inside the box (refer to diagram below), put one SumoSprings in the left side of the box and the other to the right of the box pointing the same direction. Place the bracket bundle in the middle of the box between the SumoSprings and brackets in the box. The SumoSprings and brackets should fit snug with little to no movement.

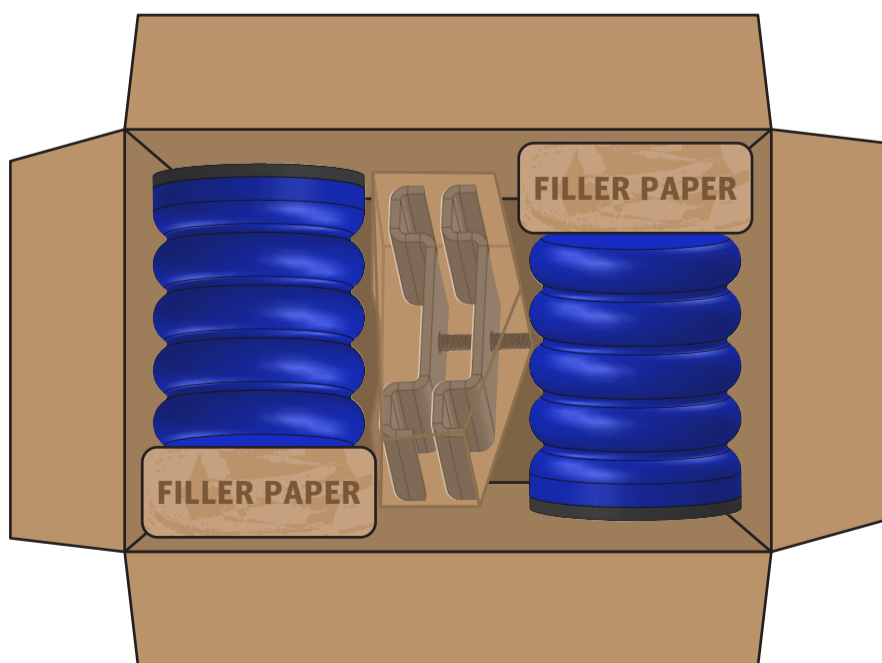

17. Place the 1 1/2" (3.81cm) bag with the blue thread locker in the box, between the SumoSprings and brackets.

18. Retrieve the installation instructions packet, which should contain the warranty card and SSI sticker, and place it on top of the components in the box.

19. Close the top of the box by completing the steps referenced in the Box Guide.

20. Using the scanner (refer to scanner instructions) print out a label.

21. Position label vertically, on the left side of the end of the box with the SuperSprings International logo side to the left (refer to Completed Kit Diagram).

22. Place the finished kit in the applicable bin.

COMPLETED KIT



COMPLETED KIT WEIGHT
7lbs (3.18 kg)