

PART NUMBER
SSA55



SCAN HERE: To watch a video of this installation



BEFORE YOU BEGIN

PARTS LIST

Item	Part #	Description	QTY
A	102011	SuperSpring SSA55	2
B	112129	Steel S Leave	4
C	112189	HD PE Roller	4
D	122414	Shackle Plate	8
E	112125	½"-13 x 5" Hex Bolt	4
F	112126	½"-13 Lock Nut	4
G	PSP-8	Poly Mount	2
H	112251	Spring Clamp	2
I	512301	3/8-16" x 1-1/2" Flange Bolt	2
J	512302	3/8" Locking Flange Nut	2

TOOLS REQUIRED

- > Floor Jack
- > Safety Jack Stands
- > Wheel Chocks
- > 3/4" Wrench/Sockets
- > 9/16" Wrench/Sockets
- > SuperSpring Installation Tool or C-Clamp

PRIMARY APPLICATIONS

- > Dodge Sprinter 2500 4 X 2 (2004 - 2009)
- > Dodge Sprinter 3500 4 X 2 (2004-2009)
- > Freightliner Sprinter 2500 4 X 2 (2002 - 2020)
- > Freightliner Sprinter 3500 4 X 2 (2002 - 2020)
- > Mercedes-Benz Sprinter 2500 4 X 2 (2010 - present)
- > Mercedes-Benz Sprinter 2500 4 X 4 (2016 - present)
- > Mercedes-Benz Sprinter 3500 4 X 2 (2010 - present)
- > Mercedes-Benz Sprinter 3500 4 X 4 (2016 - present)

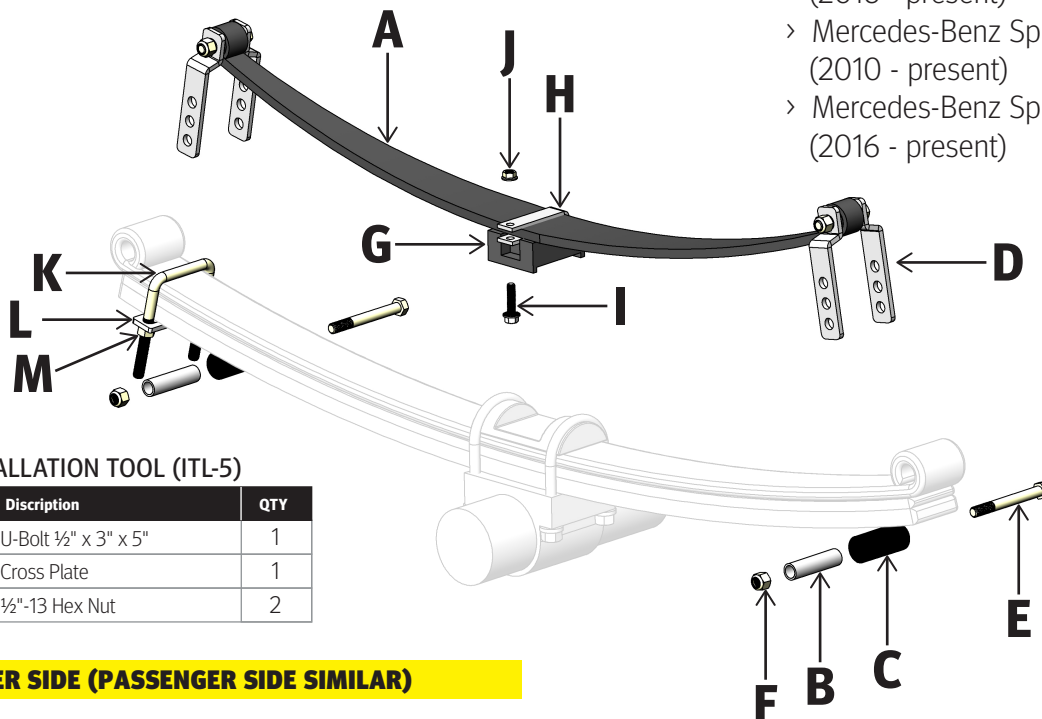

INCLUDED INSTALLATION TOOL (ITL-5)

Item	Part #	Description	QTY
K	112219	U-Bolt ½" x 3" x 5"	1
L	112203	Cross Plate	1
M	512370	½"-13 Hex Nut	2

DRIVER SIDE (PASSENGER SIDE SIMILAR)

Part Number: SSA55

Product Line: SUPERSPRINGS

Page 1

SuperSprings International, Inc.
505 Maple Avenue
Carpenteria, CA 93013

Installation Support
+1 (800) 898-0705
support@supersprings.com

superspringsint.com

SAFETY NOTICE: We recommend installation be done by a professional or persons with sound mechanical knowledge.

WARNING: These instructions are a general guide for installation. SuperSprings International, Inc. assumes no liability for the actual installation process. Consumers and installers should apply common automotive safety practices when raising and working on any vehicle. **Do not put yourself in a position where, if the vehicle were to move unexpectedly, you may be injured.** SuperSprings' products are designed to improve vehicle ride quality. Do not load any vehicle beyond the manufacturer's specifications.

Never exceed the manufacturer's Gross Vehicle Rating (GVWR) located on your vehicles identification tag.

BEFORE INSTALLATION: Ensure the vehicle is on a level surface, the parking brake is ON, with the ignition OFF, and place blocks in front of and behind the front tires to prevent the vehicle from moving.

DURING AND/OR AFTER INSTALLATION: Ensure emergency brake cables are not touching the SuperSprings. Secure any cables out of the way with zip ties or by re-routing. Ensure all A/C lines, brake cables, and frame are clear of contact or interference.

Rev. 2.0 | MAR 2022

PART NUMBER
SSA55



IMPORTANT NOTICE: Your part may have been loosely preassembled to show the final product as it will be once installed on your vehicle. Please disassemble the product before proceeding to the installation.

INSTALLATION

1. Park the vehicle on a hard, level surface and engage the emergency brake and turn on ignition. Place chocks in front and behind wheels to prevent rolling. Observe all safety precautions and wear safety glasses.
2. Raise the rear of vehicle to allow the axle to hang freely and support the frame using safety jack stands. Removal of the wheel is optional, but will make installation easier.

NOTE: Refer to the diagram on page 1.

3. Place PSP-8 pad [ITEM G] on the spring-plate between the factory u-bolts with steel channel facing up as in the diagram.
4. Prepare the SuperSpring for installation by removing the Hardware [ITEMS E & F] from the end of each shackle.
5. Place the SSA55 SuperSpring [ITEM A] so it is resting on the PSP-8 [ITEM G] above the factory leaf pack. Ensure that the threads of the spring eye bolts are facing outboard away from the frame.
6. Slide the Spring Clamp [ITEM H] around the SuperSpring and through the steel channel of the PSP-8 from the inboard side so the holes are outboard toward the wheel.
7. Insert the 3/8-16 x 1-1/2" Flange Bolt [ITEM I] upwards through the two holes of the Spring clamp and install the 3/8" Locking Flange Nut [ITEM J] leaving it loose for now.
8. Adjust the position of the SuperSpring front to back so that it has optimum clearance to the body and chassis.
9. Rotate the legs of the front and rear shackles downward so one is on each side of factory leaf pack.
10. Starting at the front, on multi-leaf spring packs, place the Square U-bolt [ITEM K] over the factory leaf pack just behind the shackle position. Place the Cross Plate [ITEM L] under the factory leaf pack and onto the legs of the Square U-bolt and install a 1/2"-13 Hex Nut [ITEM M] on each leg of the Square U-bolt. Evenly tighten the nuts so that the leaf pack is clamped together tightly. For single leaf applications disregard this step.

Part Number: SSA55

Product Line: SUPERSPRINGS

Page 2

SuperSprings
International, Inc.
505 Maple Avenue
Carpenteria, CA 93013

Installation Support
+1 (800) 898-0705
support@supersprings.com

superspringsint.com

SAFETY NOTICE: We recommend installation be done by a professional or persons with sound mechanical knowledge.

WARNING: These instructions are a general guide for installation. SuperSprings International, Inc. assumes no liability for the actual installation process. Consumers and installers should apply common automotive safety practices when raising and working on any vehicle. **Do not put yourself in a position where, if the vehicle were to move unexpectedly, you may be injured.** SuperSprings' products are designed to improve vehicle ride quality. Do not load any vehicle beyond the manufacturer's specifications.

Never exceed the manufacturer's Gross Vehicle Rating (GVWR) located on your vehicles identification tag.

BEFORE INSTALLATION: Ensure the vehicle is on a level surface, the parking brake is ON, with the ignition OFF, and place blocks in front of and behind the front tires to prevent the vehicle from moving.

DURING AND/OR AFTER INSTALLATION: Ensure emergency brake cables are not touching the SuperSprings. Secure any cables out of the way with zip ties or by re-routing. Ensure all A/C lines, brake cables, and frame are clear of contact or interference.

Rev. 2.0 | MAR 2022

PART NUMBER
SSA55



IMPORTANT NOTICE: Your part may have been loosely preassembled to show the final product as it will be once installed on your vehicle. Please disassemble the product before proceeding to the installation.

INSTALLATION

11. Pull the front shackle down (Large C-clamp or SuperSprings installation tool may be needed) until the bottom hole of the shackle leg is below the factory spring pack. Place the Steel Sleeve [ITEM B] into the Poly Roller [ITEM C] and position between the shackle legs. Insert the ½"-13 x 5" Hex Bolt [ITEM E] into the bottom hole of the inner shackle leg, through the Steel Sleeve, and out the bottom hole of the outer shackle leg so the threads are pointed outboard, away from the frame. Thread on the ½"-13 Nyloc Nut [ITEM F] and torque to 35 ft. lbs.

NOTE: If more preload is desired, the rollers and hardware may be installed in the middle or upper holes, but it is recommended to start with the bottom holes.

12. Remove the ITL-5: Square U-bolt, Cross Plate, and ½" Hex Nuts from the factory leaf pack and reinstall on the rear.

13. Using a heavy-duty clamp or SuperSprings installation tool, compress the rear of the SuperSpring and attach the rear shackle in the same way as the front.

14. Remove the ITL-5: Square U-bolt, Cross Plate, and ½" Hex Nuts from the factory leaf pack.

15. Ensure that there is adequate clearance of the SuperSpring in all areas. If any clearance issues are found, adjust the spring front to back or increase the pre load on the shackles by using one of the upper holes.

16. Tighten the PSP Spring Clamp Plate hardware [ITEM H].

17. Repeat steps 3 through 16 on the other side of the vehicle.

18. Lower the vehicle and remove all jacks and chocks.

19. Recheck installation to confirm proper clearance of the SuperSpring to all AC lines, brake lines, body, and chassis components.

20. Register the warranty for your SuperSprings International part. A warranty card can be found in the box your part came in.

Part Number: SSA55		Product Line: SUPERSPRINGS		Page 3
<p>SuperSprings International, Inc. 505 Maple Avenue Carpinteria, CA 93013</p> <p>Installation Support +1 (800) 898-0705 support@supersprings.com</p> <p>superspringsint.com</p>	<p>SAFETY NOTICE: We recommend installation be done by a professional or persons with sound mechanical knowledge.</p> <p>WARNING: These instructions are a general guide for installation. SuperSprings International, Inc. assumes no liability for the actual installation process. Consumers and installers should apply common automotive safety practices when raising and working on any vehicle. Do not put yourself in a position where, if the vehicle were to move unexpectedly, you may be injured. SuperSprings' products are designed to improve vehicle ride quality. Do not load any vehicle beyond the manufacturer's specifications.</p>		<p>Never exceed the manufacturer's Gross Vehicle Rating (GVWR) located on your vehicles identification tag.</p> <p>BEFORE INSTALLATION: Ensure the vehicle is on a level surface, the parking brake is ON, with the ignition OFF, and place blocks in front of and behind the front tires to prevent the vehicle from moving.</p> <p>DURING AND/OR AFTER INSTALLATION: Ensure emergency brake cables are not touch-ing the SuperSprings. Secure any cables out of the way with zip ties or by re-routing. Ensure all A/C lines, brake cables, and frame are clear of contact or interference.</p>	
	Rev. 2.0 MAR 2022			