

PART NUMBER

**SSR-114-47/54**



**BEFORE YOU BEGIN**

**PRIMARY APPLICATIONS**

- > Ford F-250 Super Duty 4 X 2 (1999 - 2016)
- > Ford F-350 Super Duty 4 X 2 (1999 - 2016)

**TOOLS REQUIRED**

- > Floor Jack
- > Safety Jack Stands
- > Wheel Chocks
- > 9/16" Wrench
- > 13mm & 15mm Wrench
- > 13mm & 15mm Socket

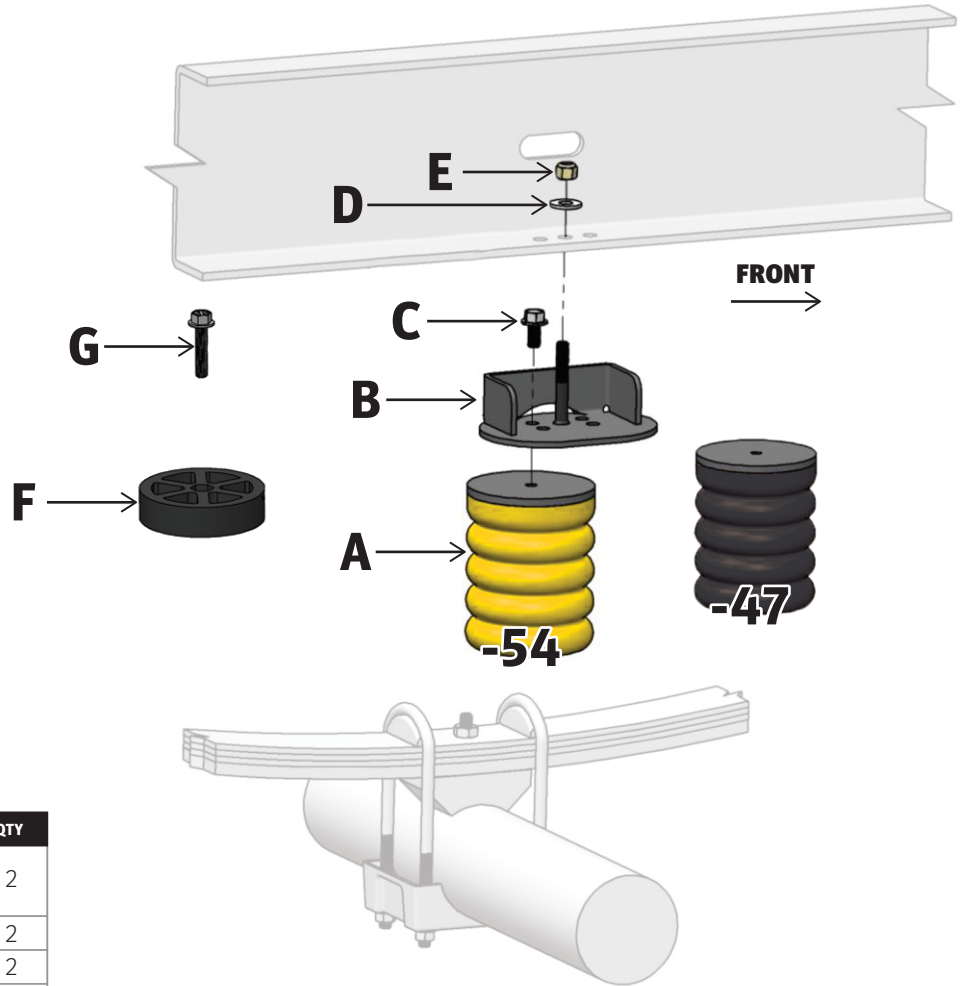

**PARTS LIST**

Item	Part #	Description	QTY
A	511404-38	Sumosprings Yellow -54	2
	511421-38	Sumosprings Black -47	
B	512349	Mounting Bracket	2
C	512207	3/8-16 x 3/4" Hex Bolt	2
D	512227	3/8 Flat Washer	2
E	512323	3/8-16 Nylock Nut	2
F	512117	1" Spacer	2
G	512274	3/8-16 x 1-3/4" Hex Bolt	2

**DRIVER SIDE (PASSENGER SIDE SIMILAR)**

**Part Number: SSR-114-47/54**

**Product Line: SUMOSPRINGS REAR**

**Page 1**

**SuperSprings International, Inc.**  
505 Maple Avenue  
Carpenteria, CA 93013

**Installation Support**  
+1 (800) 898-0705  
support@supersprings.com

superspringsint.com

**SAFETY NOTICE:** We recommend installation be done by a professional or persons with sound mechanical knowledge.

**WARNING:** These instructions are a general guide for installation. SuperSprings International, Inc. assumes no liability for the actual installation process. Consumers and installers should apply common automotive safety practices when raising and working on any vehicle. **Do not put yourself in a position where, if the vehicle were to move unexpectedly, you may be injured.** SuperSprings' products are designed to improve vehicle ride quality. Do not load any vehicle beyond the manufacturer's specifications.

Never exceed the manufacturer's Gross Vehicle Rating (GVWR) located on your vehicles identification tag.

**BEFORE INSTALLATION:** Ensure the vehicle is on a level surface, the parking brake is ON, with the ignition OFF, and place blocks in front of and behind the front tires to prevent the vehicle from moving.

**DURING AND/OR AFTER INSTALLATION:** Ensure emergency brake cables are not touching the SuperSprings. Secure any cables out of the way with zip ties or by re-routing. Ensure all A/C lines, brake cables, and frame are clear of contact or interference.

REV. 2.0 | JAN 2022

PART NUMBER

**SSR-114-47/54**



**IMPORTANT NOTICE:** Your part may have been loosely preassembled to show the final product as it will be once installed on your vehicle. Please disassemble the product before proceeding to the installation.

**INSTALLATION**

1. Park vehicle on level hard surface. Place wheel chocks in front and behind the front wheels to prevent rolling. Observe all safety precautions and wear safety glasses.
2. Raise the rear of the vehicle allowing the axle to hang free and rest the frame on the safety jack stands rated for the weight of the vehicle. Removal of the rear wheels is optional.
3. Starting on the driver side un-bolt and remove the factory Bump Stop from the underside of the frame and set aside. Some older model trucks have convoy clips that will interfere with the brackets. The convoy clips need to be removed before installation of the SumoSPrings. To remove the convoy clips, grind or drill out the rivets that hold it to the frame.
4. Assemble the parts as indicated in the diagram. Attach the SumoSpring [ITEM A] to the Mounting Bracket [ITEM B] using the 3/8-16 x 3/4" Hex Bolt [ITEM C]. Be sure to use the hole that will be closest to the rear and furthest outboard toward the wheel of the vehicle.
5. Attach the Mounting Bracket [ITEM B] to the underside of the frame using the 3/8 Flat Washer [ITEM D] and 3/8-16 Lock Nut [ITEM E]. Install mounting stud in the same hole as the factory bump stop.
6. If more support is required, install the 1" Spacer [ITEM F] between the Mounting Bracket [ITEM B] and the SumoSpring [ITEM A] using the 3/8-16 x 1-3/4" Hex Bolt [ITEM G].
7. Repeat steps 3 through 6 on the passenger side of the vehicle.
8. If rear wheels were removed you can now reinstall the rear wheels and torque wheel nuts to manufacturers specifications.
9. Jack up vehicle, remove safety jack stands.
10. Remove wheel chocks from the front wheels.
11. Register the warranty for your SuperSprings International part. A warranty card can be found in the box your part came in.

<b>Part Number: SSR-114-47/54</b>		<b>Product Line: SUMOSPRINGS REAR</b>	<b>Page 2</b>
<p>SuperSprings International, Inc. 505 Maple Avenue Carpenteria, CA 93013</p> <p>Installation Support +1 (800) 898-0705 support@supersprings.com</p> <p>superspringsint.com</p>	<p><b>SAFETY NOTICE:</b> We recommend installation be done by a professional or persons with sound mechanical knowledge.</p> <p><b>WARNING:</b> These instructions are a general guide for installation. SuperSprings International, Inc. assumes no liability for the actual installation process. Consumers and installers should apply common automotive safety practices when raising and working on any vehicle. <b>Do not put yourself in a position where, if the vehicle were to move unexpectedly, you may be injured.</b> SuperSprings' products are designed to improve vehicle ride quality. Do not load any vehicle beyond the manufacturer's specifications.</p>	<p>Never exceed the manufacturer's Gross Vehicle Rating (GVWR) located on your vehicles identification tag.</p> <p><b>BEFORE INSTALLATION:</b> Ensure the vehicle is on a level surface, the parking brake is ON, with the ignition OFF, and place blocks in front of and behind the front tires to prevent the vehicle from moving.</p> <p><b>DURING AND/OR AFTER INSTALLATION:</b> Ensure emergency brake cables are not touch-ing the SuperSprings. Secure any cables out of the way with zip ties or by re-routing. Ensure all A/C lines, brake cables, and frame are clear of contact or interference.</p>	<p>REV. 2.0   JAN 2022</p>