

PART NUMBER

SSR-128-40-2/47-2



BEFORE YOU BEGIN

PRIMARY APPLICATIONS

- > Ford F-250 Super Duty 4 x 4 (2017 - present)
- > Ford F-350 Super Duty 4 x 4 (2017 - present)

TOOLS REQUIRED

- > Floor Jack
- > Jack Stands
- > Wheel Chocks
- > 9/16 Wrench & Sockets
- > Ratchet
- > 7/32 Allen Wench

PARTS LIST

| Item | Part # | Discription | QTY |
|------|--------|------------------------------------|-----|
| A | 511419 | SumoSprings Blue -40 | 2 |
| | 511418 | SumoSprings Black -47 | |
| B | 512344 | Upper Bracket 1 | 2 |
| C | 512345 | Upper Bracket 2 | 2 |
| D | 512162 | Lower Bracket | 2 |
| E | 512244 | 5/16" Flat Washer | 8 |
| F | 512323 | 3/8-16" Nyloc Nut | 8 |
| G | 112282 | Clamp Plate | 2 |
| H | 512356 | 3/8-16" Clip Nut | 4 |
| I | 512340 | 3/8-16 x 1" FHCS | 4 |
| J | 512207 | 3/8-16 x 3/4" Serrated Flange Bolt | 6 |
| K | 512302 | 3/8" Flanged Lock Nut | 8 |
| L | 512296 | 3/8-16 x 3" FHCS | 4 |
| M | 112196 | 3/8 7" x 5" U-Bolt | 2 |

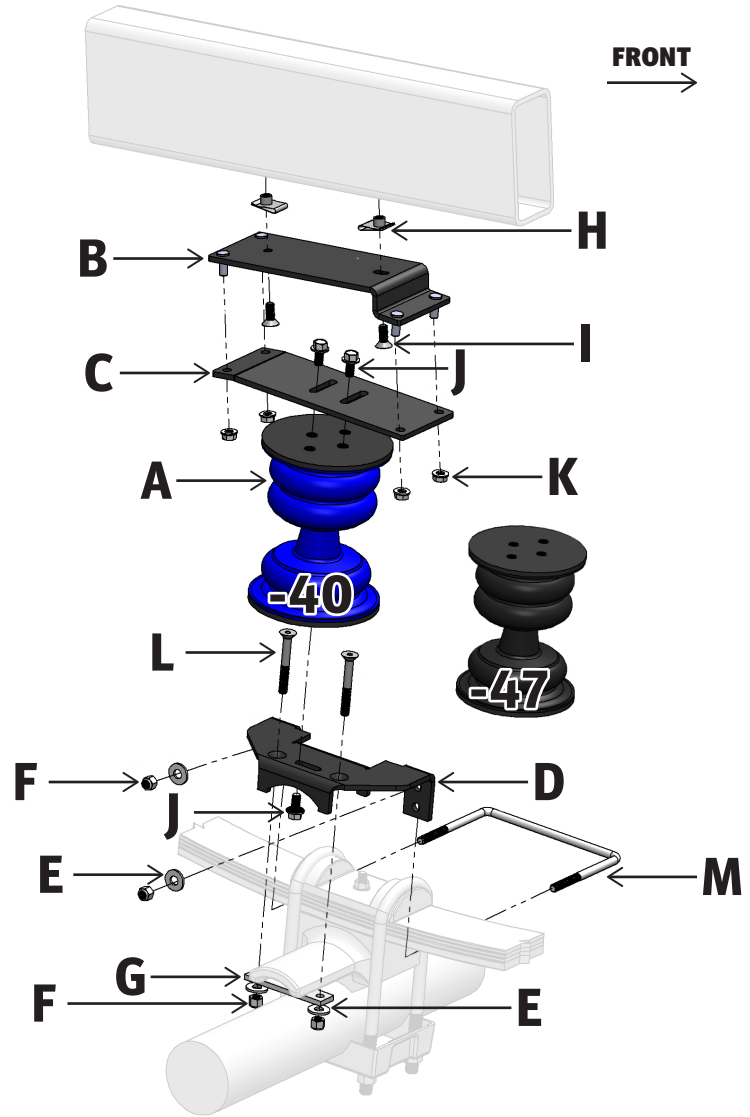

DRIVER SIDE (PASSENGER SIDE SIMILAR)

Part Number: SSR-128-40-2/47-2

Product Line: SUMOSPRINGS REAR

Page 1

SuperSprings
International, Inc.
505 Maple Avenue
Carpenteria, CA 93013

Installation Support
+1 (800) 898-0705
support@supersprings.com

superspringsint.com

SAFETY NOTICE: We recommend installation be done by a professional or persons with sound mechanical knowledge.

WARNING: These instructions are a general guide for installation. SuperSprings International, Inc. assumes no liability for the actual installation process. Consumers and installers should apply common automotive safety practices when raising and working on any vehicle. **Do not put yourself in a position where, if the vehicle were to move unexpectedly, you may be injured.** SuperSprings' products are designed to improve vehicle ride quality. Do not load any vehicle beyond the manufacturer's specifications.

Never exceed the manufacturer's Gross Vehicle Rating (GVWR) located on your vehicles identification tag.

BEFORE INSTALLATION: Ensure the vehicle is on a level surface, the parking brake is ON, with the ignition OFF, and place blocks in front of and behind the front tires to prevent the vehicle from moving.

DURING AND/OR AFTER INSTALLATION: Ensure emergency brake cables are not touching the SuperSprings. Secure any cables out of the way with zip ties or by re-routing. Ensure all A/C lines, brake cables, and frame are clear of contact or interference.

REV. 2.02 | APR 2022

PART NUMBER

SSR-128-40-2/47-2



IMPORTANT NOTICE: Your part may have been loosely preassembled to show the final product as it will be once installed on your vehicle. Please disassemble the product before proceeding to the installation.

INSTALLATION

1. Park vehicle on level hard surface. Place wheel chocks in front and behind the front wheels to prevent rolling. Observe all safety precautions and wear safety glasses.
2. Raise the back of the vehicle allowing the axle to hang free and rest the frame on the safety jack stands rated for the weight of the vehicle. Removal of the rear wheels is optional.
3. Starting on the driver side unbolt and remove the factory Bump Stop from the underside of the frame and remove the factory studs that are clipped into the frame.
4. Attach two 3/8-16 Clip Nuts [ITEM H] onto the frame where the factory studs were positioned. Ensure that the threaded portion is up inside the frame.
5. Using the two 3/8-16 x 1" FHCS [ITEM I], attach the Upper Bracket 1 [ITEM B] to the frame with the bent end toward the front of the vehicle as in the diagram on page 1. Place a drop of the blue loctite on the threads of each bolt.
6. Using two 3/8-16 x 3/4" Serrated Flange Bolts [ITEM J] attach the top half of the SumoSprings [ITEM A] to the Upper Bracket 2 [ITEM C]. Leave the bolts slightly loose so that the position of the SumoSprings can be adjusted.
7. Place the Upper Bracket 2 [ITEM C] and SumoSprings assembly [ITEM A] onto the studs of the Upper Bracket 1 [ITEM B]. The end of the Upper Bracket 2 with the bend goes toward the rear of the truck as in the diagram. Fasten the brackets together with four 3/8" Flanged Lock Nuts [ITEM K].
8. Place one 3/8-16 x 3/4" Serrated Flange Bolt [ITEM J] into the slot of the Lower Bracket [ITEM D] as seen in the diagram. (Temporarily thread one 3/8" Flanged Lock Nut loosely onto the bolt to keep it in place).
9. Place the lower bracket on the bump stop contact perch and position tight to the leaf pack.
10. Place two 3/8-16 x 3" FHCS [ITEM L] down through the lower bracket.
11. Place the 3/8 7"x 5" U-Bolt [ITEM M] around the factory u-bolts and below the leaf pack so that the ends protrude through the holes in the Lower Bracket [ITEM D] and fasten securely with the 5/16" Flat Washers [ITEM E] and 3/8-16" Nyloc Nuts [ITEM F].

| | | | |
|--|--|--|-----------------------------|
| Part Number: SSR-128-40-2/47-2 | | Product Line: SUMOSPRINGS REAR | Page 2 |
| <p>SuperSprings International, Inc. 505 Maple Avenue Carpenteria, CA 93013</p> <p>Installation Support +1 (800) 898-0705 support@supersprings.com</p> <p>superspringsint.com</p> | <p>SAFETY NOTICE: We recommend installation be done by a professional or persons with sound mechanical knowledge.</p> <p>WARNING: These instructions are a general guide for installation. SuperSprings International, Inc. assumes no liability for the actual installation process. Consumers and installers should apply common automotive safety practices when raising and working on any vehicle. Do not put yourself in a position where, if the vehicle were to move unexpectedly, you may be injured. SuperSprings' products are designed to improve vehicle ride quality. Do not load any vehicle beyond the manufacturer's specifications.</p> | <p>Never exceed the manufacturer's Gross Vehicle Rating (GVWR) located on your vehicles identification tag.</p> <p>BEFORE INSTALLATION: Ensure the vehicle is on a level surface, the parking brake is ON, with the ignition OFF, and place blocks in front of and behind the front tires to prevent the vehicle from moving.</p> <p>DURING AND/OR AFTER INSTALLATION: Ensure emergency brake cables are not touching the SuperSprings. Secure any cables out of the way with zip ties or by re-routing. Ensure all A/C lines, brake cables, and frame are clear of contact or interference.</p> | <p>REV. 2.02 APR 2022</p> |

PART NUMBER

SSR-128-40-2/47-2



IMPORTANT NOTICE: Your part may have been loosely preassembled to show the final product as it will be once installed on your vehicle. Please disassemble the product before proceeding to the installation.

INSTALLATION

12. Place the Clamp Plate [ITEM G] over the ends of the 3/8-16 x 3" FHCS [ITEM L] and fasten tight to the bottom of the bump stop perch using the 5/16" Flat Washers [ITEM E] and 3/8-16" Nyloc Nuts [ITEM F]. (Be careful not to over tighten the lower bracket hardware to the point of bending it).
13. Hold the head of the 3/8-16 x 3/4" Serrated Flange Bolt [ITEM J] in place with a wrench, remove the temporary 3/8" nut and add some loctite to the threads of the bolt.
14. Place the lower half of the SumoSprings onto the bolt and turn the SumoSprings to thread it into place.
15. Raise the axle so the upper and lower halves of the SumoSprings are close enough to be aligned and tighten the mounting bolts for each.
16. Repeat steps 3 through 15 on passenger side of truck.
17. If rear wheels were removed you can now reinstall the rear wheels and torque wheel nuts to manufacturers specifications.
18. Jack up vehicle, remove safety jack stands.
19. Remove wheel chocks from the front wheels.
20. Register the warranty for your SuperSprings International part. A warranty card can be found in the box your part came in.

Part Number: SSR-128-40-2/47-2

Product Line: SUMOSPRINGS REAR

Page 2

SuperSprings International, Inc.
505 Maple Avenue
Carpenteria, CA 93013

Installation Support
+1 (800) 898-0705
support@supersprings.com

superspringsint.com

SAFETY NOTICE: We recommend installation be done by a professional or persons with sound mechanical knowledge.

WARNING: These instructions are a general guide for installation. SuperSprings International, Inc. assumes no liability for the actual installation process. Consumers and installers should apply common automotive safety practices when raising and working on any vehicle. **Do not put yourself in a position where, if the vehicle were to move unexpectedly, you may be injured.** SuperSprings' products are designed to improve vehicle ride quality. Do not load any vehicle beyond the manufacturer's specifications.

Never exceed the manufacturer's Gross Vehicle Rating (GVWR) located on your vehicles identification tag.

BEFORE INSTALLATION: Ensure the vehicle is on a level surface, the parking brake is ON, with the ignition OFF, and place blocks in front of and behind the front tires to prevent the vehicle from moving.

DURING AND/OR AFTER INSTALLATION: Ensure emergency brake cables are not touch-ing the SuperSprings. Secure any cables out of the way with zip ties or by re-routing. Ensure all A/C lines, brake cables, and frame are clear of contact or interference.

REV. 2.02 | APR 2022